



1333 NW Eastman Parkway, Gresham, Oregon 97030-3813  
Phone 503-618-2355 • Fax 503-666-8330  
GreshamOregon.gov/fire  
GFD@GreshamOregon.gov

---

## **Fire Prevention Planning Guide for Special Events & Seasonal Sales**

This guide outlines the fire safety requirements found in the 2022 Oregon Fire and Building Codes and the Oregon Fire Code Technical Advisory No. 08-01 for Special Events such as Fairs, Trade Shows, Carnivals, Seasonal Sales, and Common Venue Events. The Gresham Fire Department (GFD) is committed to ensuring safety for all vendors and participants at community events and has created this guide for your use. Utilizing information in this guide will help you host an organized event with minimal last-minute disruptions to correct code violations.

This guide summarizes fire safety requirements to be used by event promoters and/or permit applicants. This guide is a tool to be used by an event planner to prepare your Fire Prevention Permit Application and to advise vendors of the fire safety requirements for the event. In GFD review of the permit application you may be advised of necessary additions and/or requirements that must be met before the event occurs. All events must comply with the applicable requirements in this guide.

The 2022 Oregon Fire and Building codes apply to all events permitted or unpermitted.

### **When is a Fire Prevention Permit required?**

A permit is required when any of the following\* are proposed to operate:

- ASSEMBLY
- CARNIVAL
- FAIR
- EXHIBITION
- TENT OR CANOPY
- SEASONAL SALES
- AERIAL DISPLAYS

\*For definitions see page 2

### **How do I apply for a permit?**

- Call the Life Safety Division at 503-618-2355 to find out if your event requires a permit.
- Permit applications can be obtained at the Life Safety Division Office located in the City of Gresham Public Safety Building at 1333 NW Eastman Parkway in Gresham, or from the department's website at <http://www.GreshamOregon.gov/Fire-Permits>.

### **When will I receive my permit?**

- A fire inspector will contact you to schedule a fire inspection prior to the opening of your event. There may be additional inspections conducted in the duration of the permit to confirm continued compliance with conditions as approved.
- Once your fire inspection is complete and all violations corrected you will be issued your Fire Prevention Permit. Your permit will only be valid during the dates listed on the

permit. An extension of the permit may only be granted by request with possible additional inspections by GFD. Inspection fees for permit extension may apply.

- Your permit must be posted on-site for the duration of your event.
- Any permit issued may be suspended or revoked by GFD if the conditions of the permit have been violated OR any false statement or misrepresentation of information provided in the application or plans from which the permit issuance was based were made.

### Table of Contents

1. Definitions	Page 2
2. Site & Seating Plans	Page 3
3. Candles, Heaters, and Open Flames	Page 3
4. Combustible Materials	Page 4
5. Cooking and Food Warming Equipment	Page 4
6. Decorative Materials	Page 5
7. Electrical	Page 5
8. Occupant Load	Page 6
9. Seating Arrangement	Page 6
10. Exiting and Aisle Widths	Page 6
11. Portable Fire Extinguishers	Page 6
12. Flame Retardants and Fire Resistive Materials	Page 7
13. Propane (LPG) Use	Page 8
14. Exhibit Booths and Sales Displays	Page 8
15. Tents and Canopies	Page 8
16. Tents and Canopies used for Cooking	Page 9
17. Vehicle Display and/or Parking	Page 10
18. Camping and RV Parking	Page 10
19. Fenced Events-Beer Gardens and Concerts	Page 10
Appendix I	Page 11
Appendix II	Page 12

#### **Section 1 Definitions**

**Assembly:** the temporary gathering of 50 or more persons for such purposes as deliberation, education, instruction, worship, entertainment, amusement, drinking, and/or dining. **A permit is required at the discretion of the Fire Marshal.**

**Canopy:** A canopy differs from a tent in that 75% of its sidewall space is open. Enclosing a canopy's sidewall creates a tent.

**Carnival:** a mobile enterprise principally devoted to offering amusement or entertainment to the public in, upon, or by means of temporary structures, rides, or any combination of both.

**Cooking:** includes the use of open flame cooking tops, fryers, skillets, kettles, woks, microwaves, ovens, barbeques, warming trays using open flames, and other specialty cookware.

**Exhibition:** an event in which the display of products or services is organized to bring together the provider and user of the products or services.

**Fair:** an enterprise principally devoted to the exhibition of products of agriculture or industry in connection with the operation of amusement rides or devices, or concession stands.

**Occupant Load:** the maximum number of people permitted inside an area.

**Tent:** a temporary structure, enclosure or shelter constructed of fabric or pliable material supported by any manner other than air.

## **Section 2 Site & Seating Plans**

Planners with events that require a permit must attach a scaled and detailed floor or site plan to the permit application.

The plans must show the following (if applicable):

- Location and width of all stages, platforms, physical structures, fences, exit doors, aisles in large exhibitor areas, and the main event aisle ways.
- Seating arrangement-including any tables and chairs.
- Location, size, and identification number of exhibits, booths, cooking booths, and other display spaces.
- Location and size of propane (LPG) containers and/or helium tanks.
- Location and width of the fire lanes and the location of fire hydrants.
- Distance from tents to property lines, fences, and structures.
- Location of fire extinguishers, egress lighting, and exit signs.
- Description of decorations (i.e., draping, balloons, misc. decorations, etc.)
- Vehicle layout (for vehicle displays).
- Location of dumpsters and waste receptacles.
- Designated smoking areas (if provided).
- Combustible vegetation must be kept a minimum of 10 feet from tents, booths, and tree sales areas.

## **Section 3 Candles, Heaters, and Open Flames**

Candles, heaters, and other open flame devices add ambience and comfort to a special event but must be used with extra caution. Listed below are safe permitted uses of candles, heaters, and open flames.

- Candelabras shall be secured in place and located away from exits, combustibles and people.
- Handheld candles shall not be passed from one person to another while lit.
- Flammable liquid (canned heat) used for food preparation is limited to 1 oz. containers or 1-quart containers with a controlled pouring device that limits flow to 1 oz. serving.
- If food preparation is being done at a table where guests are seated, a wet towel must be readily available to smother a possible fire or cool a burn.
- Use approved liquid or solid fuel non-spill containers for decorative lighting. Secure to prevent overturning. Decorative shades must be non-combustible.

- Class I and II flammable liquids (i.e., kerosene and gasoline) and propane shall not be used for decorative or lighting purposes indoors, in tents or under canopies.
- Only electrically powered portable heating equipment with high limit/tip-over protection may be used in buildings, tents, and canopies.
- Patio/umbrella type heaters (gas or electric) are allowed for outside venues as long as they maintain clearance from combustibles per listing and are secured to prevent tipping. Must be located at least 5 feet from buildings and exits or exit discharges.
- Luminaries may be used provided they are treated with a fire retardant and are placed on a non-combustible surface such as soil, concrete, tile, etc. Luminaries may only be used under adult supervision and must be located at least 5 feet from buildings and exits or exit discharges. **Aerial luminaries are prohibited.**

#### **Section 4 Combustible Materials**

- Combustible merchandise being displayed should be limited to a reasonable quantity.
- Reserve supplies and merchandise shall be kept in closed containers and stored neatly.
- Waste materials, such as empty cardboard boxes and packing materials, must be removed from the exhibit area daily.
- Promoters shall ensure that trash pickup is provided for the event and the exhibitors daily.

#### **Section 5 Cooking & Food Warming Equipment**

If cooking is approved for your event, you must use an approved appliance and provide an adequate number and type of fire extinguishers. A minimum 4A: 40 BC portable fire extinguisher and wet towel are to be available in each cooking area. A Type K portable fire extinguisher must be available if deep fat frying or woks are used.

For additional fire extinguisher requirements see [Section 11 Portable Fire Extinguishers](#).

Propane/butane is prohibited to be used indoors see [Section 13 Propane \(LPG\) Use](#)

Additional requirements must be met for cooking in tents, canopies or booths, see [Section 16](#).

For examples of approved cooking equipment options see [Appendix II](#).

Listed below are approved cooking/warming appliances and conditions for use:

- Microwave and electric ovens
- Electric steam tables
- Electric cook top griddles
- Electric single well deep fat fryer or wok
- Natural gas cooking appliances that have been approved by the Building Department. Provide written confirmation of approval (i.e., inspection card).
- Gas fired appliances shall be placed on a non-combustible surface. If the manufacturer's instructions require the equipment to be vented to the outside, it must be done.
- Multi-well deep fat frying equipment is prohibited unless an approved self-contained hood, ventilation, and suppression system is provided.
- Single-well cooking equipment using cooking oils shall:
  1. Have lids for immediate use to cover and smother a fire.
  2. Be limited to 288 sq. inches of cooking surface.
  3. Be placed on a non-combustible surface.

4. Be separated from other single-well cooking equipment by a minimum horizontal distance of 2 ft.

**\*\*\*Any cooking device that is indoors, in a trailer, and/or in a combustible booth and creates grease-laden vapors shall be provided with an approved hood and extinguishing system or be the type with a self-closing lid or other form of self-extinguishment approved by GFD.**

**All hood ventilating systems are required to be installed in accordance with the Oregon Mechanical Specialty Code and be cleaned prior to the start of the event and as often as needed to prevent the build-up of grease during the event.**

### **Section 6 Decorative Materials**

Decorative materials are typically used to make a sales area more appealing to customers. Many of the combustible items used such as wood lath, decorative fabric and plastic or foam signs, are a fuel source for fast developing fires. The following requirements apply to decorative materials:

- Combustible decorative materials, excluding table covers, shall be flame resistant. Wood less than 1/4" thick shall be treated with a flame-retardant coating.
- Foam plastic objects including mannequins, murals, and signs shall cover less than 10% of a wall, ceiling, or floor area.

*Note: If the material is not flame-resistant, fire-retardant products can be purchased and applied to the material by the vendor or by a professional.*

### **Section 7 Electrical**

Safe use of electrical cords will keep your event's power need running without interruption. For examples of approved cords please see Appendix I. The following are specific requirements for the use of extension cords and power strips/taps:

- Residential type (small gauge cord) extension cords are not allowed to be used. Extension cords shall be a minimum 14-gauge, three conductor size with polarized or grounded plug and receptacle.
- Home-made or spliced cords are not to be used.
- Extension cords may be used when plugged directly into the outlet. Chaining of cords or power strips is prohibited.
- Multi-plug adapters (i.e., cube adapters) are not allowed in commercial or temporary occupancies.
- Relocatable power taps may be used when plugged directly into an outlet and equipped with a built-in circuit breaker.
- Extension cords used outdoors must be plugged into a GFCI protected outlet.
- Protect cord if it will be subject to foot traffic or unusual weight or tension. Cords may be protected by plastic (office style) cord covers or wood constructed (ramp style). Duct tape may be used to secure a cord if it is placed perpendicular across the cord, not horizontally covering the cord.
- Decorative lighting may be used according to manufacturer's specifications.

An electrical permit is required if temporary electrical service or equipment is installed. Contact the building department for electrical permit information.

## **Section 8 Occupant Load**

A building or outside venue used for exhibits, entertainment, feeding or instructing more than 50 people shall be assigned an occupant load. It is the responsibility of the building owner and/or the promoter to ensure that the maximum number of people allowed in an area is not exceeded.

- Established occupant load limits shall be maintained by the facility. An occupant load sign (issued by GFD) may be required to be posted.
- A means to monitor the occupant load in an area shall be used. One approved method is to use hand-held counters to track incoming and outgoing people.
- Crowd managers shall be provided for crowds of more than 1,000 people. The minimum number of crowd managers is one for every 250 people.
- Standby personnel may be required for the sole purpose of maintaining occupant load limits.

## **Section 9 Seating Arrangements**

Seating plans shall be included in your Site & Seating Plan (Section 2). Adequate exiting must be provided when developing a seating plan.

- When using over 200 chairs, the chairs must be bonded together in groups of three or more.
- The minimum distance between front/back of folding chairs is 12 inches, measured from the front edge of the seat to the back edge of the seatback in front of it.

## **Section 10 Exiting and Aisle Widths**

Adequate exits must be provided for all events.

- Aisles and exits shown on approved sites or floor plans must always be kept clear and free of obstructions.
- Easels, signs, displays, etc. must not be placed in the aisles or exit paths from all areas of the event.
- Exits and aisles may only be used for exiting. No displays, tables or other objects may be placed in hallways or exits.
- Provide a minimum of 48-inch aisles for exiting when using over 200 chairs and 36-inch aisles for 200 chairs or less.

## **Section 11 Portable Fire Extinguishers**

Portable fire extinguishers are required at all events. A fire extinguisher is an effective means to extinguish a small fire but must only be used by a person who is confident in their abilities to use it safely and effectively. Most commercial buildings will have fire extinguishers distributed throughout however additional ones may be required depending upon your event use of the building. Note fire extinguisher locations on your site plan when applying for permit. Meet the extinguisher requirements for your type of event.

To provide adequate fire extinguisher coverage the following must be met:

- At least one minimum 2A: 10 BC portable fire extinguisher must be provided.
- A minimum 4A: 40 BC extinguisher is required if an open flame and/or cooking will be present. The extinguisher must be located within 30 feet of the cooking activity.
- A minimum 3A: 40 BC extinguisher must be provided when a generator is in use. The extinguisher must always be in the vicinity of the generator when operating.

- Minimum 2A water extinguisher is required for Fireworks Sales.
- Extinguishers shall have a current service tag (serviced within the last 12 months).
- Place extinguishers adjacent to exits and/or in the paths of egress.
- Promoter/planner may require each booth/vendor to provide an extinguisher for their area or extinguishers must be provided with maximum travel distance of 75 feet (unless otherwise required by GFD) from any point in the event space.
- Extinguishers must be in plain sight, mounted so that the top of the extinguisher is no higher than 4 feet above the floor.
- Notify vendors/booth operators of the locations of fire extinguishers.
- For OUTDOOR events the following matrix may be used to plan for an adequate number of extinguishers.

Portable Fire Extinguisher Requirements for Outdoor Events			
Type of Event	Extinguisher Placement Requirements		
Select the category that most resembles your event. If the category is not shown, contact GFD	Maximum 75-foot travel distance to extinguishers	Maximum 50-foot travel distance to extinguishers	Event Promoter may opt to require each vendor or booth to have an extinguisher.
<b>Carnival midways</b>	X		X
<b>Carnival rides</b>	Every ride shall have at least one 2A: 10BC portable extinguisher		
<b>Cooking booths using oil, any event</b>	Cooking booths shall have at least one 4A: 40BC portable extinguisher. Deep fat frying or use of WOKs require a Type K extinguisher		
<b>Fair midways</b>	X		X
<b>Fireworks</b>	Every discharge area shall have at least one 2A 40BC extinguisher		
<b>Street markets or fairs</b>	X		X
<b>Tents</b>	see section 15	see section 15	
<b>Note:</b> During the review of your permit application the reviewer may determine additional portable extinguishers are required.			

## **Section 12 Flame Retardants and Fire Resistive Materials**

Flame retardants are used to treat a variety of materials to inhibit the spread of fire. Some materials, such as most plastic tarps, cannot be treated with flame retardants unless done by the manufacturer. Products treated with flame retardants must bear proof of treatment and/or be provided to the fire inspector upon request. Proof of treatment may consist of providing a copy of the product label or specification sheet and/or verification that the product was applied according to manufacturer's specifications.

Fire resistive materials/products must bear label from manufacturer indicating it meets fire resistive standards.

### **Section 13 Propane (LPG) Use**

LPG may not be used indoors. For outdoor use, the following requirements must be met:

- LPG tanks may only be located on the exterior of buildings, booths, portable concessions, or tents.
- LPG tanks shall be a minimum of 10 feet from combustible vegetation and trash containers.
- LPG tanks shall be located a minimum of 20 feet from a potential ignition source.
- LPG tanks shall be located so they are not in contact with direct flame, high heat situations or sparks.
- LPG tanks must be secured from falling. Method of securing tank must be sturdy and capable of preventing tank movement.

### **Section 14 Exhibit Booths and Sales Displays**

- The travel distance within a booth or vendors exhibit area to an accessible exit aisle shall not exceed 50 feet.
- Booths constructed of combustible materials, foam, cloth, plastic, or wood (using less than 2" x 4" dimension lumber) must comply with flame retardant requirements in Section 12.
- Booths, tables and/or displays must be solid/stable and not susceptible to collapse.
- Booths, tables, and display areas shall be clearly defined so exhibits do not encroach into aisles and exits.
- Booths, displays and products must not block exit doors, electrical panels; roll up fire doors, fire alarm pull stations or sprinklers.
- Keep combustible displays and/or products at least 18 inches below the bottom of sprinkler heads or 24 inches from ceiling in a building with no sprinkler system.
- Keep combustibles at least 36 inches from heat sources.
- Booths or displays must not interfere with fire sprinkler or fire alarm system performance.

### **Section 15 Tents and Canopies**

Tents exceeding 200 sq. feet and canopies exceeding 400 sq. feet require a Fire Prevention Permit. Permit application must include a site and seating plan.

Tents must meet the following requirements:

- Tents and canopies are not allowed inside a structure.
- Tents and canopies shall maintain 20 feet from structures, property lines or right of ways.\* To determine required distances, support ropes and guy wires are considered part of the tent or canopy.
- Tents and canopies shall be roped, braced, and anchored.
- Tents and canopies must be made of fire-resistant material (must bear label from manufacturer indicating so) or be treated with an approved flame retardant.
- Decorative materials used in tents shall be flame retardant.
- Post NO SMOKING signs inside and/or outside tent.
- When multiple tents or canopies are arranged or set side by side, the aggregate length shall not exceed 150 feet without a 20-foot fire break.



- 20 feet shall be maintained between cooking tents/canopies/booths and non-cooking tents/canopies/booths and other structures.\*
- Outdoor cooking that produces sparks or grease laden vapors shall not be performed within 20 feet of a tent or canopy. **Exception:** Cooking appliances with approved ventilation.
- No open flame devices are allowed inside tents. For cooking in tents see requirements in Section 16.
- Provide one minimum 2A: 10 BC fire extinguisher for every 3,000 square feet of floor area. See Section 11 for additional fire extinguisher requirements.
- Provide minimum 12-foot clearance around all sides of tents and canopies unless arranged or set side by side.\*
- The maximum distance to an exit shall not exceed 100 feet.
- Tents and canopies must be provided with exiting as follows:
  1. Occupant loads up to 10, one exit 6 feet wide.
  2. Occupant load 10 to 199, two exits 6 feet wide
  3. Occupant load 200-499, three exits 6 feet wide
  4. Occupant load 500-999, four exits 8 feet wide
  5. Occupant load 1,000-2000, five exits 10 feet wide.
  6. An additional 10' wide exit to be added for each additional 1,000 people.
  7. Exits must be spaced evenly around the tent perimeter. For assistance in determining your occupant load contact GFD.
- Provide exit signs above each exit. For occupant capacity over 100 exit signs must be illuminated and provided with a back-up power supply.
- Overnight sleeping is not allowed in tents.

\*Separations may be reduced to 10 feet under special consideration as approved by GFD.

### **Section 16 Tents and Canopies used for Cooking**

In addition to the requirements in Section 15, tents and canopies used for cooking must meet the following requirements:

- Cooking Booths must have 10-foot clearance on two sides.
- Provide a minimum 4A: 40 BC fire extinguisher. See Section 11, Portable Fire Extinguishers, for additional requirements that may apply.
- Cooking and heating equipment must be kept a minimum of 10 feet from exit or exit aisles and any combustible materials.
- Appliances with open flame cook tops, fryers, skillet frying, and woks *shall not* be located inside a tent. Such appliances *may* be located under a canopy if the appliance is equipped with adequate venting, to release cooking related by-products from under the canopy to the outside.
- An umbrella (treated with a fire retardant or made of fire-resistant material) or a non-combustible hard lid to cover the cooking appliance may be used to meet health department requirements for covering cooking operations.
- Propane tanks must be placed and/or stored at least 10 feet from booths, tents, and canopies. All tanks must be secured from falling and not subject to extreme heat or open flame.

- Hay, straw, and similar combustible materials shall not be stored inside or within 30 feet of a tent or canopy used for cooking or public assembly.

### **Section 17 Vehicle Display and/or Parking**

Indoor display of vehicles, boats and recreational vehicles shall comply with the following:

- Batteries shall be disconnected. **Exception:** electric hybrid vehicles.
- Vehicles shall not block or obstruct exits.
- Fuel tanks shall be locked or sealed (may use duct tape).
- Fuel tanks shall be no more than ¼ full or contain no more than 5 gallons of fuel.
- Fueling or de-fueling shall not be done inside a building or tent.

### **Section 18 Camping and RV Parking**

Camping and or RV parking associated with a special event must comply with applicable requirements in this guide.

- Clear space of 10 feet must be maintained between Camping and RV parking and any tent, building and/or combustible storage.
- Camping and RV parking is limited to the duration of the event unless approved by GFD.
- Camping and RV parking must also comply with any applicable locally adopted codes and/or rules.

### **Section 19 Fenced Events- Seasonal Sales, Beer Gardens and Concerts**

Fenced events shall meet the following requirements:

- Fenced areas with an occupant load of more than 50 people require at least two exits. Additional exits may be required depending upon the occupant load.
- Post occupant load sign (provided by GFD).
- Exits shall not be chained or locked and must be easily opened from inside the fenced area.
- Exits shall be marked with an exit sign.
- Egress and emergency lighting may be required at night or after sunset.
- Exit doors and gates shall swing in the direction of egress travel.
- Fencing must be adequately secured to the ground.
- Christmas Trees must be kept at least 10 feet from the property line.

### **Section 20 Food Carts Attending Events**

Food carts in attendance, where cooking produces grease laden vapors, shall have a fire suppression system with documentation showing it has been serviced within the past 6 months. A current Class K fire extinguisher will also need to be in the cart- or they will not be allowed to operate.

**Appendix I**

Approved Extension Cords and Power Taps



## Appendix II

Below are examples of cooking booth construction and/or configurations that may be approved for use at special events. The size, design or appearance of examples is intended to represent cooking booth construction by concept only. Such options may be deemed safe and in compliance with the Oregon Fire Code.

### Option 1: Open flame cooking with no frying or deep fat frying.

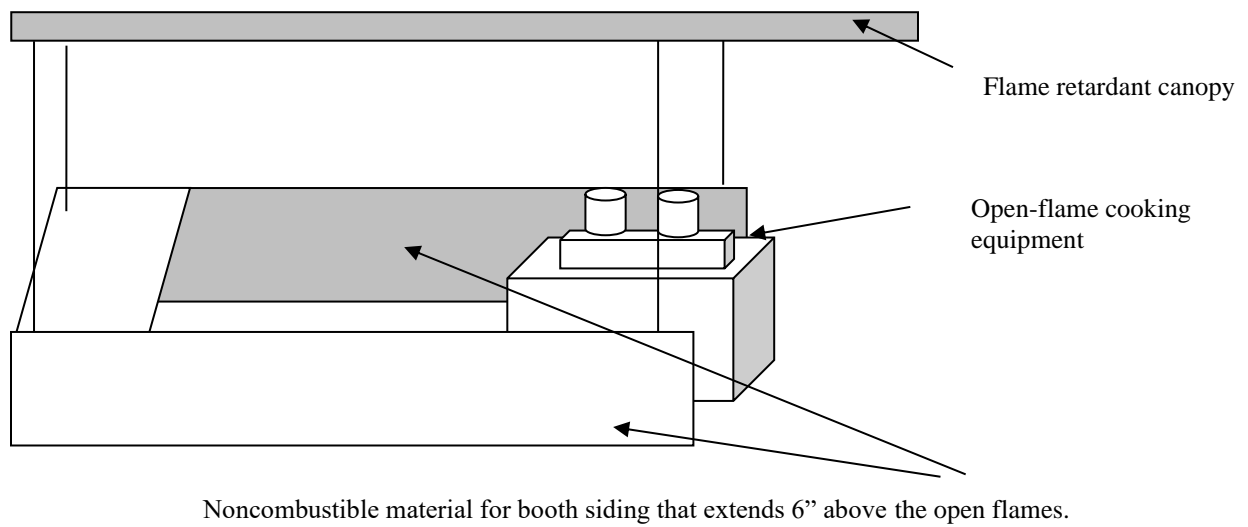

### Option 2: Open flame cooking with no frying or deep fat frying.

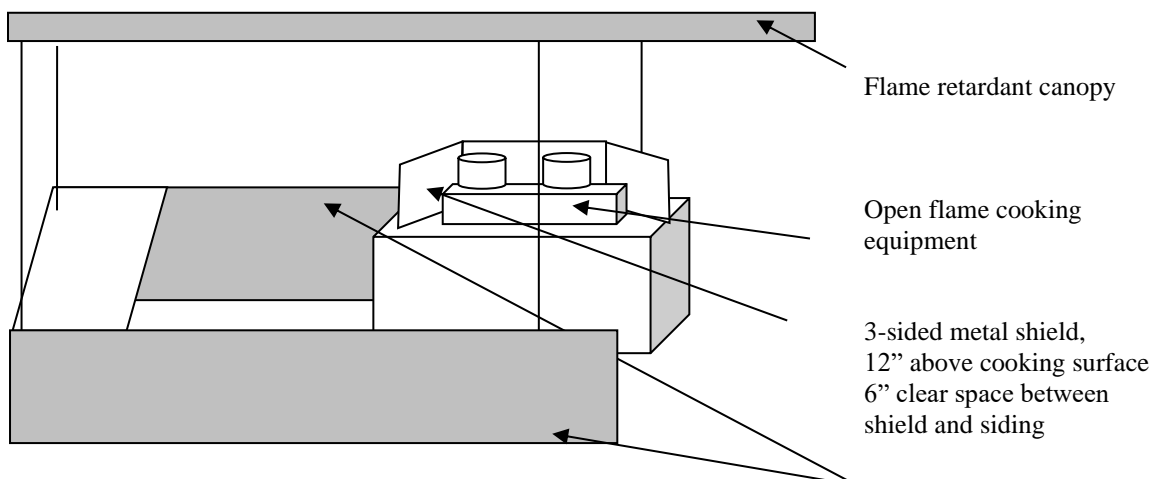

Noncombustible material for booth siding that extends 6'' above the open flames.

Refer to these drawings for **additional configuration options** for open flame equipment, deep-fat frying, or the use of woks.

If a booth is constructed with combustible materials i.e., fabric, wood, plastic, etc. it cannot have open flame equipment, deep-fat frying, or wok frying processes occurring under the booth covering or near its siding.

**Option 3:** Open-flame cooking or deep fat frying.

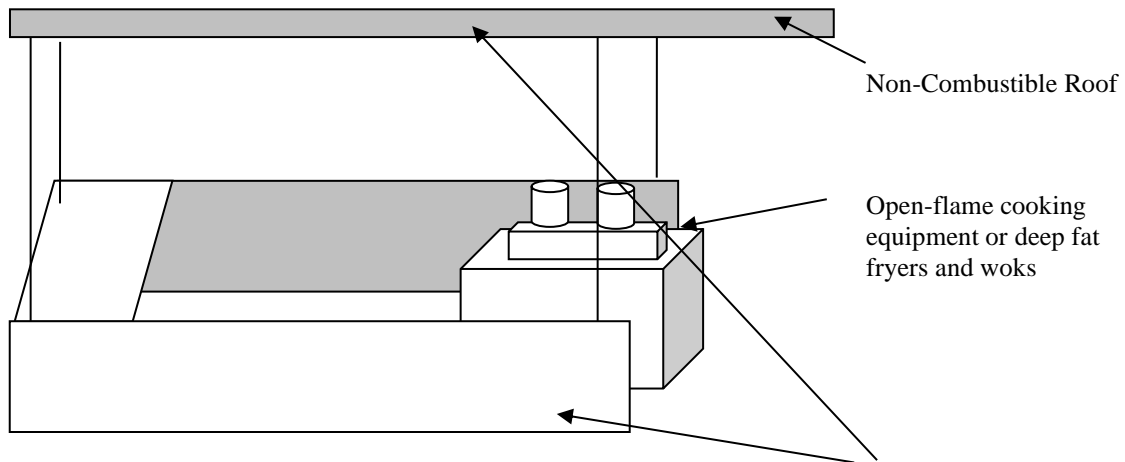

If the booth siding and top are made of noncombustible materials i.e., metal, cement board, sheetrock, etc. then open-flame, deep-fat frying or wok type equipment may be used inside booth. Booth framework may be constructed of wood.

**Option 4:** Open-flame cooking, deep fat frying and woks.

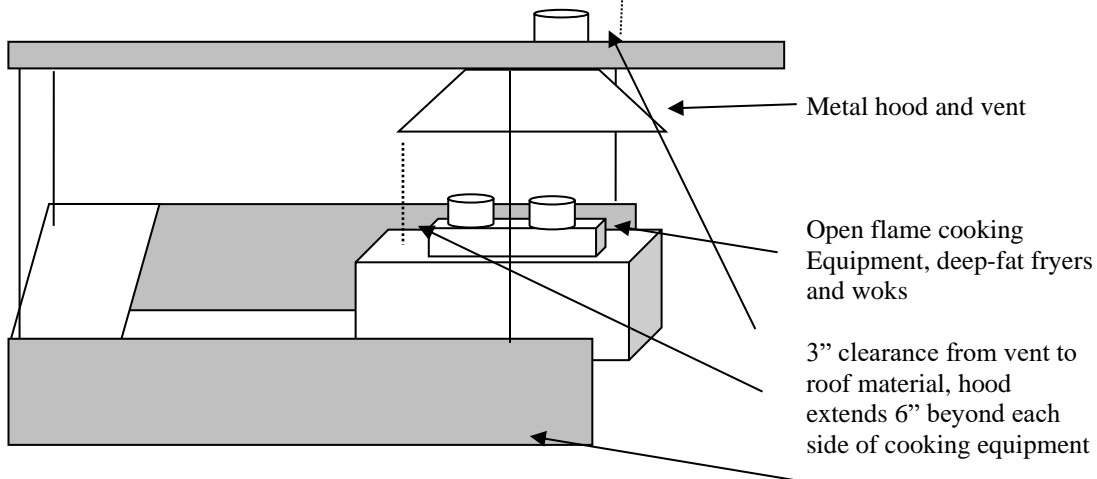

A booth can be made of fire retardant treated combustible material e.g., wood, fabric, etc. provided it:

1. Has a metal hood that vents at least 24" above the roof.
2. The hood extends at least 6" beyond the perimeter of the cooking equipment.
3. The hood vent has at least 3" clearance from the roofing material *or* a double-walled vent is used.

- 12" clear space must be maintained between the cooking equipment and the sides of the booth unless the shield is used from Option 2 then 6" is permitted.

**Option 5:** Open-flame cooking, deep fat frying and woks.

